



Frankford Associates, Inc.
4500 Torresdale Avenue
Philadelphia, PA 19124

Phone: 215-289-3434

Fax: 215-289-4470

www.frankfordonline.com

Fulton Classic *Fuel-fired Vertical Tubeless Boilers and* **The EDGE** *High Performance Vertical Tubeless Boilers*

Classic Steam boilers 4-60 HP and The EDGE High Performance Units 4-30 HP

Horizontal and Vertical Condensate Return Systems and Blow-down Separators

Built/certified in accordance to ASME
Boiler and Pressure Vessel Code



Entire Boiler is a UL Listed
Packaged Boiler

4-60 HP CSA Approved

R081205

Fulton Gas-Fired, Oil-Fired, and Combination Gas/Oil-Fired Steam Boilers

Since Fulton's invention of the vertical tubeless boiler in 1949, Fulton has been the leading U.S. manufacturer of this type of boiler. For over 50 years, more than 100,000 boilers have been produced and distributed world-wide.

Every Fulton boiler is built and stamped to the ASME Code and registered with the National Board of Boiler and Pressure Vessel Inspectors. Fulton boilers are UL listed packaged boilers -- not just the burner or electrical components -- the entire boiler and they are CSA approved.

A vertical tubeless boiler is a relatively simple design, offering years of trouble-free operation.

Many Fulton boilers over 30 years of age are still in operation today. There are no tubes or coils to rust or burn out periodically, therefore, no retubing costs, no downtime. No downtime means increased productivity.

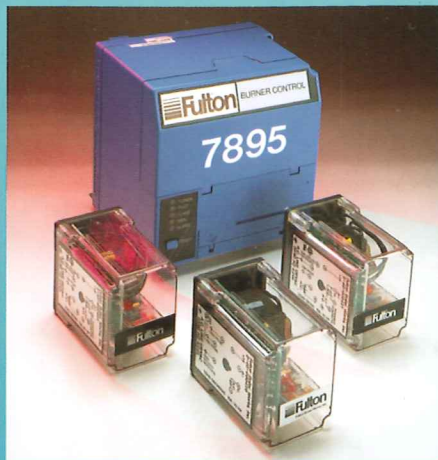

Complete control panel box houses all necessary operating components.

The 7800 Series Microprocessor based controls are standard. A trouble shooting display module is optional. Fulton's commitment to continuous product improvement is

reflected in the efficiency, quality, and ruggedness of these superior standard fuel-fired boilers.

All Fulton Boilers can be ordered with a polished stainless steel jacket.

Ask your Fulton distributor how little extra it can cost for stainless.



If you want more efficiency with the same vertical tubeless design Fulton has The EDGE.

The thickness of the pressure vessel is no less than 5/16" (7.94mm).



and it does have the edge over The Classic. Fuel to steam efficiencies in the low 80's. It is available in 4 - 6 - 15 - 20 and 30 HP. The EDGE has the same time proven top mounted matched burner with the downward cyclonic flame and features the Fulton engineered Flue Gas Enhancing System (FGE). A highly efficient two pass design, the Fulton FGE system works by using a massive heat transfer surface with high velocity flue gases traveling over a cylindrical grid of heat convection fins. Through controlled velocities these fins transmit additional heat evenly to the outer side of the water vessel, creating high efficiencies with lower stack temperatures.

Dramatic stack temperature reductions.

With the Fulton FB-F, The EDGE, stack temperatures can be from 100-150°F below standard two pass designs and have cut previous fuel bills in half!

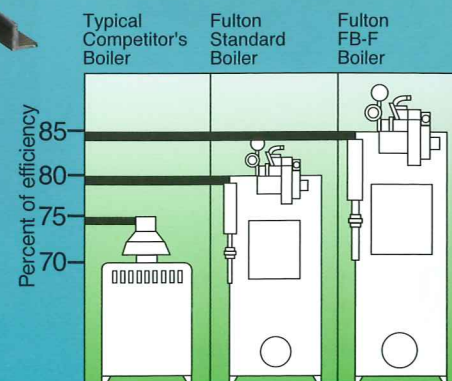

Fulton's unique features begin with simplicity

The furnace (pressure vessel) is, simply stated, a "pipe within a pipe". The top mounted Fulton power burner sends a spinning cyclonic flame into and down the center furnace chamber.

Features of the Fulton Vertical Tubeless Boiler

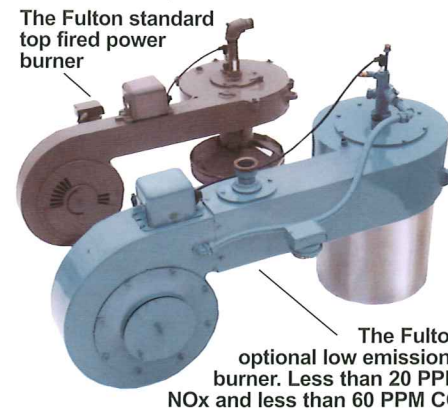

Fulton fuel-fired boilers can be ordered with combination fuel capabilities or be converted to combination fuels simply and economically.

All fuel-fired boilers feature the Fulton designed and manufactured top mounted down fired forced draft burner.

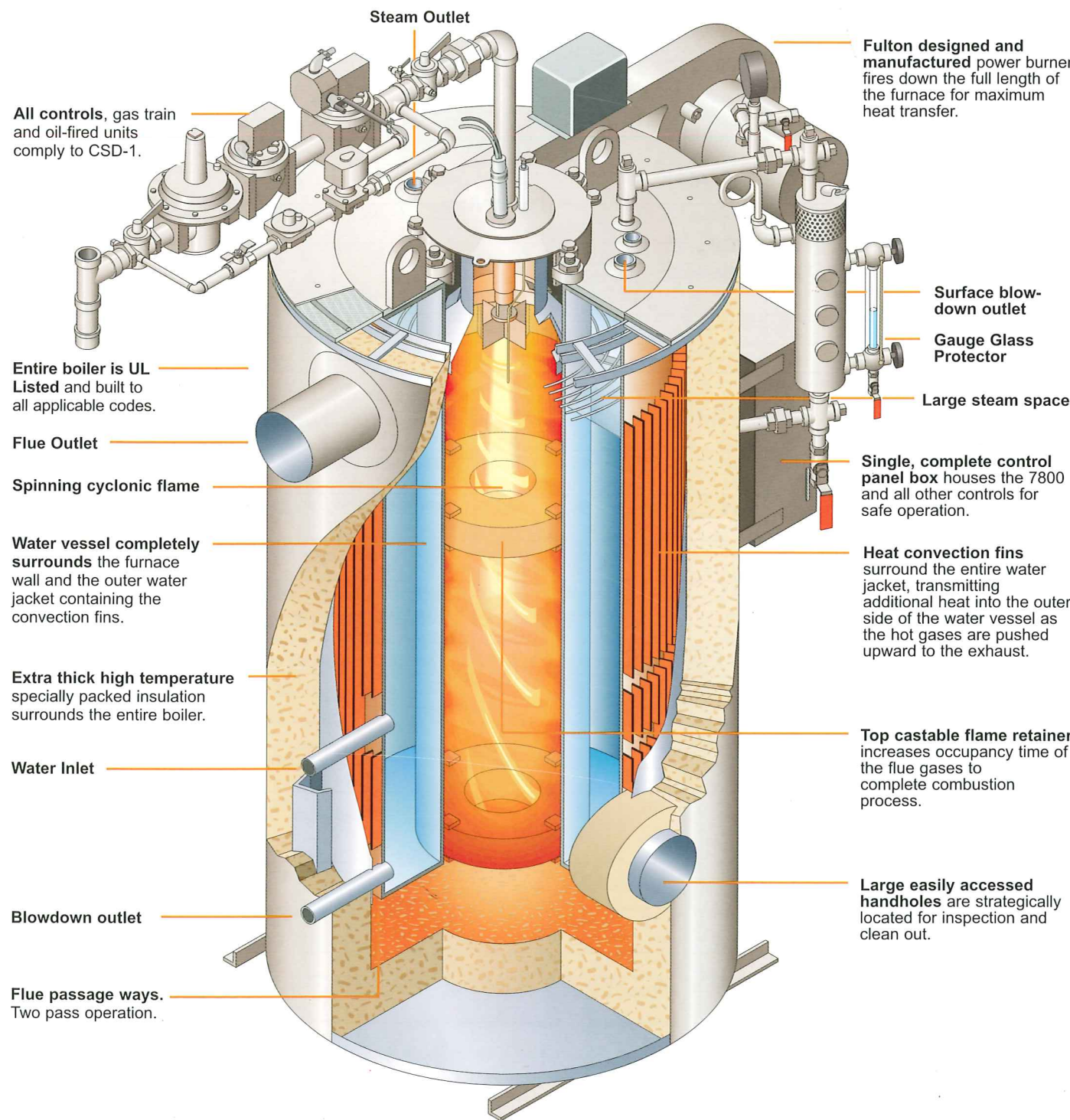
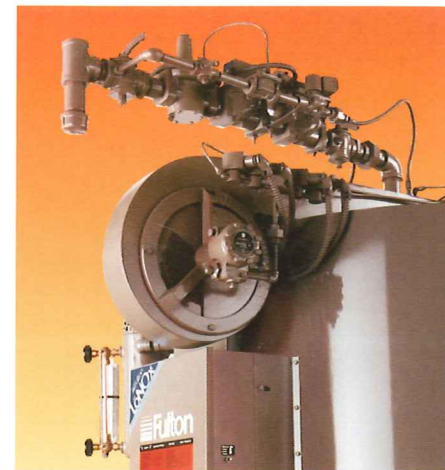

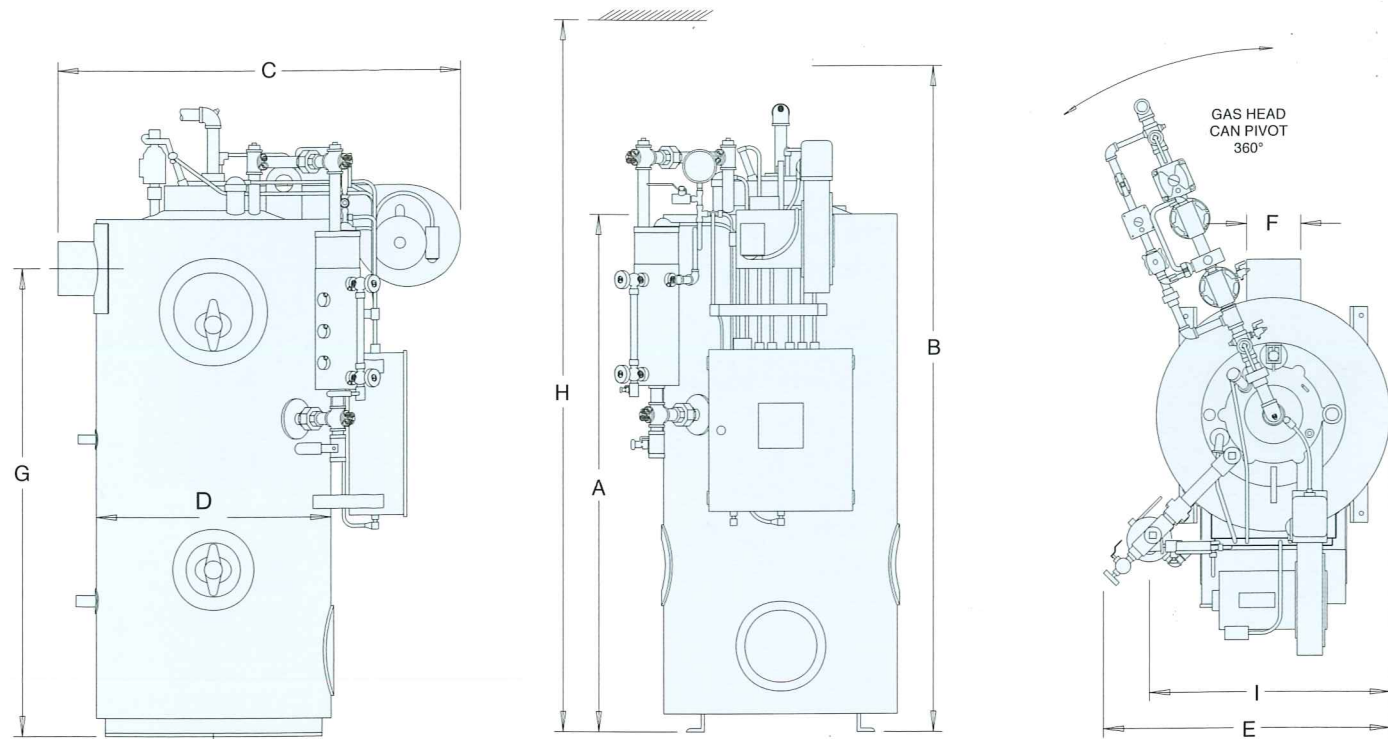

Side View

Front View

Top View

Dimensions and Weights

Classic Models FB-A, The EDGE Models FB-F

		4	6	9.5	10	15	20	25	30	50	60
Classic Models FB-A		4	6	9.5	10	15	20	25	30	50	60
The EDGE Models FB-F		4	6	N/A	10	15	20	N/A	30	N/A	N/A
Unit Size:	HP	4	6	9.5	10	15	20	25	30	50	60

Heights and Widths

		4	6	9.5	10	15	20	25	30	50	60
A. Boiler Height	IN	47.5	57.5	67.5	63.5	69.5	72.5	74.5	82.5	87.5	93.5
	MM	1207	1461	1715	1613	1765	1842	1892	2096	2223	2375
B. Boiler Height With Trim* & Fuel Train Assembly	IN	65	75	85	80.5	86.5	92.5	94.5	102	106.5	120
	MM	1651	1905	2159	2045	2197	2350	2400	2591	2705	3048
C. Overall Depth Stack to Burner Fan Housing	IN	44	44	39	46	47	60	60	67	78	78
	MM	1118	1118	991	1168	1194	1524	1524	1702	1981	1981
D. Boiler Diameter	IN	26	26	26	28	30	39	39	46	55	55
	MM	660	660	660	710	760	990	990	1170	1400	1400
E. Overall Width with Water Column	IN	33	33	33	33.5	35.5	43	43	49	57	57
	MM	838	838	838	851	902	1091	1091	1244	1448	1448
F. Flue Outlet Diameter	IN	6	6	6	6	8	10	10	12	12	12
	MM	152	152	152	152	203	254	254	305	305	305
G. To Center of Flue Outlet	IN	42	52	62	58	63	66	66	73.5	79	85
	MM	1070	1320	1575	1473	1600	1675	1676	1867	2007	2159

Minimum Clearances

		4	6	9.5	10	15	20	25	30	50	60
H. Clearance Required for Burner Removal * ✖	IN	72	82	92	86	92	96	98	106	114	124
	MM	1828	2083	2337	2184	2337	2438	2489	2692	2896	3150
I. Opening Required for Boiler Installation With Water Column Removed	IN	26	26	26	28	30	39	39	46	55	55
	MM	660	660	660	710	760	990	990	1170	1400	1400
Front of Boiler	IN	41	41	41	41	41	41	41	41	41	41
	MM	1041	1041	1041	1041	1041	1041	1041	1041	1041	1041
Sides & Rear of Boiler	IN	18	18	18	18	18	18	18	18	18	18
	MM	914	914	914	914	914	914	914	914	914	914

Weights

		4	6	9.5	10	15	20	25	30	50	60
Approx. Shipping Weight	LB	1400	1700	1900	2000	2280	3400	3500	4780	6526	7280
	KG	635	773	862	910	1036	1545	1588	2173	2966	3309

* This dimension is 6" less for oil-fired units 4-50 HP and 12" less for oil-fired units 60 HP.
 ✖ Add 6" for low emissions burner removal.

Specifications

Classic Models FB-A, The EDGE Models FB-F

		4	6	9.5	10	15	20	25	30	50	60
Classic Models FB-A		4	6	9.5	10	15	20	25	30	50	60
The EDGE Models FB-F		4	6	N/A	10	15	20	N/A	30	N/A	N/A
Unit Size:	HP	4	6	9.5	10	15	20	25	30	50	60

Ratings* (Sea level to 3000 ft.)

		4	6	9.5	10	15	20	25	30	50	60
Output	1000 BTUHR	134	201	318	335	502	670	838	1004	1674	2009
	1000 KCAL/HR	34	51	80	84	127	169	211	253	422	506
Steam Output	LB/HR	138	207	328	345	518	690	863	1035	1725	2070
	KG/HR	63	94	149	157	235	312	391	470	783	939

Approximate Fuel Consumption at Rated Capacity+

		4	6	9.5	10	15	20	25	30	50	60
Light Oil	GPH	1.2	1.8	2.85	3.0	4.5	6	7.5	9	15.0	18.0
	LPH	4.5	6.8	10.8	11.4	17.0	22.7	28.5	34.0	57.0	68
Propane Gas (Classic)	FT ³ /HR	67	100	157	167	250	333	413	499	832	999
	M ³ /HR	2.4	3.5	5.5	5.9	8.8	11.8	11.7	17.6	29.4	35.3
Propane Gas (EDGE)	FT ³ /HR	63	95	159	159	238	317	317	475	N/A	N/A
	M ³ /HR	2.2	3.4	N/A	5.6	8.4	11.2	N/A	16.8	N/A	N/A
Natural Gas (Classic)	FT ³ /HR	167	250	396	417	625	834	1045	1250	2085	2502
	M ³ /HR	5.9	8.8	14.0	14.7	22.1	29.5	29.7	44.2	73.6	88.4
Natural Gas (EDGE)	FT ³ /HR	159	238	397	397	595	794	794	1190	N/A	N/A
	M ³ /HR	5.6	8.4	N/A	14.0	21.0	28.1	N/A	42.0	N/A	N/A
Natural Gas Boiler Connection Size	IN	1	1	1	1	1	1.25	1.25	1.5	1.5**	2
	MM	25	25	25	25	25	32	32	38	38	51
Burner	3450 RPM/60 CY									1.5 gas	1.5 gas
Motor HP	2850 RPM/50 CY	1/3	1/3	1/3	1/3	1/3	1/3 gas	3/4	3/4	2 oil	2 oil

Electric Power Requirements (in Amps)

		4	6	9.5	10	15	20	25	30	50	60
120V, 60 CY, 1 Phase		5.2	5.2	5.2	5.2	5.2	5.2 gas	9.2	9.2	--	--
							9.2 oil				
240V, 50/60 CY, 1 Phase		2.6	2.6	2.6	2.6	2.6	2.6 gas	4.6	4.6	8.9 gas	8.9 gas
							4.6 oil			9.5 oil	9.5 oil
208V, 50/60 CY, 3 Phase		1.9	1.9	1.9	1.9	1.9	1.9 gas	3.1	3.1	4.4 gas	4.4 gas
							3.1 oil			5.7 oil	5.7 oil
240V, 50/60 CY, 3 Phase		1.6	1.6	1.6	1.6	1.6	1.6 gas	2.8	2.8	4.2 gas	4.2 gas
							2.8 oil			5.4 oil	5.4 oil
480V, 50/60 CY, 3 Phase		.8	.8	.8	.8	.8	.8 gas	1.4	1.4	2.1 gas	2.1 gas
							1.4 oil			2.7 oil	2.7 oil

Water Content

		4	6	9.5	10	15	20	25	30	50	60
	U.S. GAL	14	16	16	24	39	77	94	170	245	270
	LITERS	53	61	61	91	148	292	356	644	927	1022

*All ratings from 0 PSIG and at 212°F.
 +Consumption based on Light Oil 140,000 BTU/G/ Natural Gas 1010 BTU/ft³; Propane 2530 BTU/ft³.
 --Consult factory.
 **2"/51mm IRI and CSA
 Specifications are approximate. We reserve the right to change specifications.
 N/A-Not Available

Note:
 High pressure boilers ordered with an extra pressure control for night heating have less than rated output while operating at low pressure.

Boiler, Condensate Tank, and Blow-Down Separator

Condensate return tank should be vented and have a capacity sufficient to satisfy boiler consumption and maintain proper return tank temperature. Vent pipe should not be down-sized (may cause pressure build up in the condensate tank). Return pipes must not be insulated.

See Return System Instruction Manual.

Optional barometric damper is recommended for most installations.

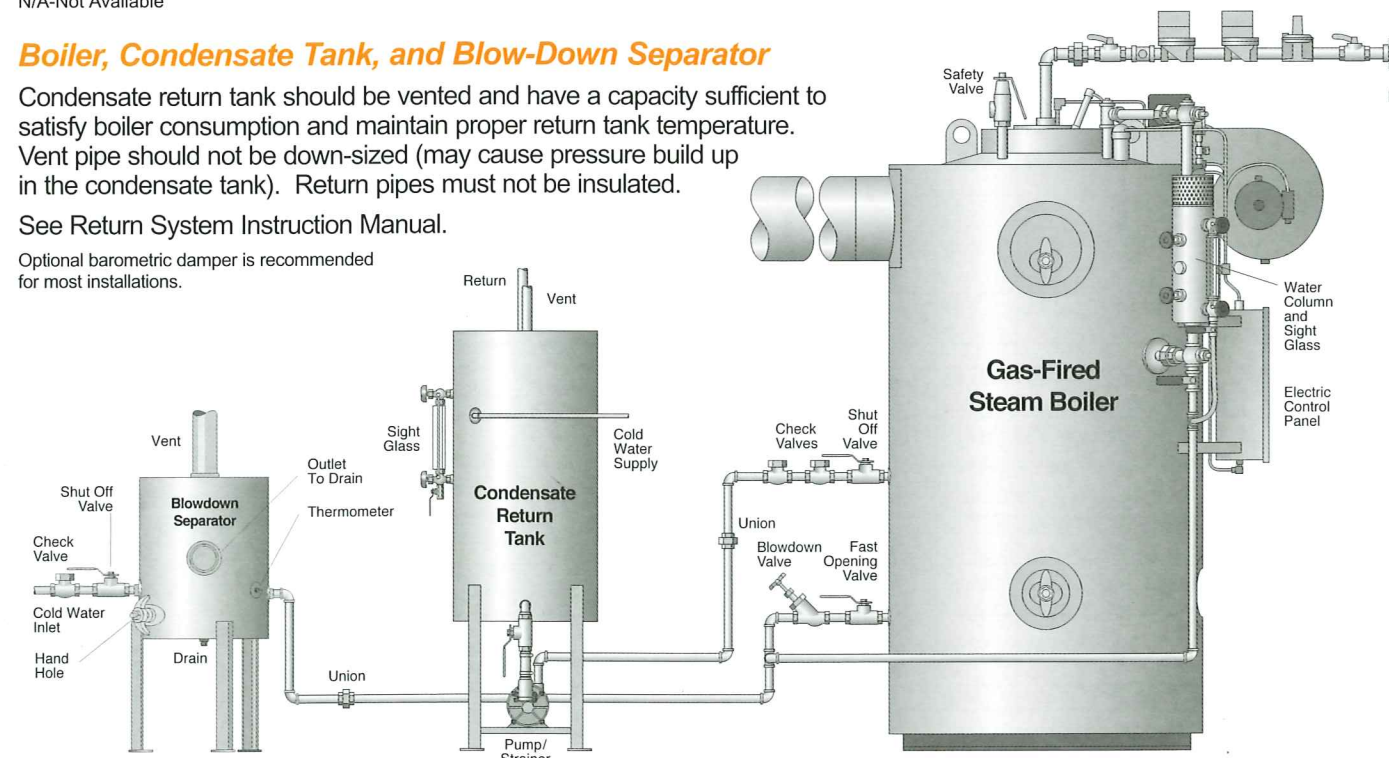

Horizontal Condensate Return Systems

Designed For All Boilers From 1 HP Up To 400 HP

Fulton condensate return systems are completely assembled with tank, stand, high pressure pump, motor strainer, float valve, shut-off valve, gauge glass assembly, with overflow and drain openings.

Features:

- Heavy gauge properly sized tanks built for quick installation and removal or replacement.
- Heavy duty feed water pump.
- Rigid welded support frame.

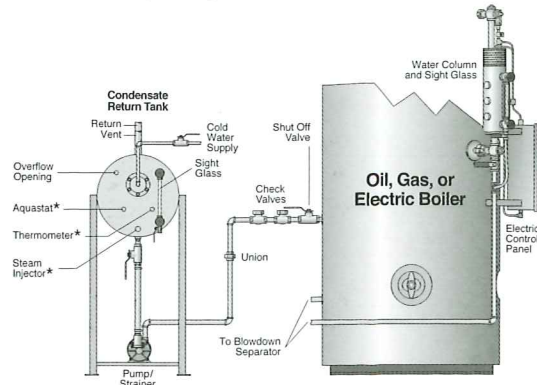

*Supplied With Optional Preheat Kit Assembly

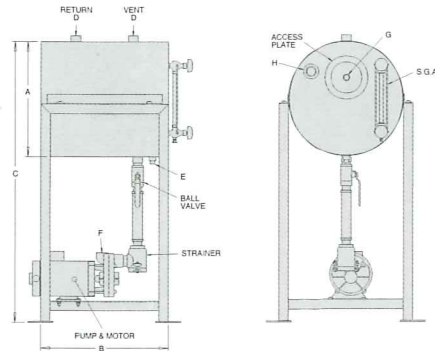

Specifications/Dimensions/Connections

Model HT	8	10	20	30	50	60	80	100	150	200	250	300	350	400
For Boiler Size HP	1-7.5	8-12.5	13-21	22-30	31-50	51-60	61-80	81-100	101-150	151-200	201-250	251-300	301-350	351-400
Full U.S. GALLONS	22	33	40	46	71	94	128	147	220	220	317	317	432	432
Capacity LITERS	83	125	151	174	269	356	485	556	833	833	1200	1200	1635	1635
Weight LBS	130	160	180	195	325	465	560	650	1190	1190	1430	1430	1670	1670
Weight KGS	59	73	82	89	148	211	254	295	540	540	649	649	757	757
DIMENSIONS														
(A) Tank Dia. IN	18	18	18	18	24	24	28	30	30	30	36	36	42	42
MM	457	457	457	457	610	610	711	762	762	762	914	914	1067	1067
(B) Tank Length IN	20	30	36	42	36	48	48	48	72	72	72	72	72	72
MM	610	762	914	1067	914	1219	1219	1219	1829	1829	1829	1829	1829	1829
(C) Overall Height IN	45	45	45	45	52	52	56	63	63	63	70	70	74	74
Floor-Top Of Tank MM	143	1143	1143	1143	1321	1321	1422	1600	1600	1600	1778	1778	1880	1880
CONNECTIONS														
(D) Vent/Return IN	1.25	1.25	1.25	1.25	2	2	2	2	2	2	2	2	2.50	2.50
MM	25	32	32	32	51	51	51	51	51	51	51	51	64	64
(E) Drain IN	.50	.50	.50	.50	1	1	1	1	1	1	1.25	1.25	1.25	1.25
MM	13	13	13	13	25	25	25	25	25	25	32	32	32	32
(F) Pump Outlet IN	1	1	1	1	1	1	1	1	*	*	*	*	*	*
MM	25	25	25	25	25	25	25	25	*	*	*	*	*	*
(G) Cold Water Inlet IN	.50	.50	.50	.50	.75	.75	.75	.75	.75	.75	.75	.75	1	1
MM	13	13	13	13	19	19	19	19	19	19	19	19	25	25
(H) Overflow Opening IN	1	1	1	1	1	1	1	1	1	1	1	1	1.25	1.25
MM	25	25	25	25	25	25	25	25	25	25	25	25	32	32
(I) Pump HP														
1 Ph. Motor	.50	.50	.75	1.50	NA	NA	NA	NA	*	*	*	*	*	*
3 Ph. Motor	.50	.50	.75	1.50	3	3	5	5	*	*	*	*	*	*
(J) Pump Motor: RPM														
3450	3450	3450	3450	3450	3450	3450	3450	1725	*	*	*	*	*	*

†Overflow Opening must be piped to drain.
*Consult Factory

Vertical Condensate Return Systems

Designed For Compact Space Saving Applications For Boilers From 1 HP up to 100 HP

Standard pump is good for 180°F maximum water temperature. Pumps for higher temperature water are available upon request.



Both the horizontal and the vertical condensate return systems are available in heavy gauge "long lasting" steel only. Vertical tanks have all the same assembly components that the horizontal tanks do.

Features

- Increased pump life under normal operation because of higher head pressure.
- Vertical return systems can be ordered separately or skid-mounted and piped to your boiler.
- Easily serviced from the top.
- Complete float assembly can be removed without draining tank.

Suggested Piping

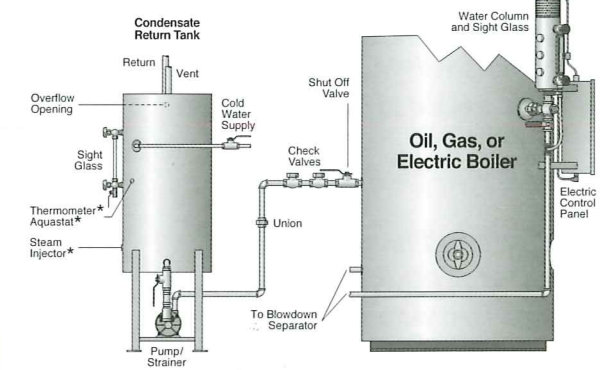

*Supplied With Optional Preheat Kit Assembly (NOTE: Aquastat Opening Is The Same Dimension Off Centerline Of Sightglass But On Opposite Side)

Specifications/Dimensions/Connection

Model VT	8	10	20	30	50	60	80	100
For Boiler Size HP	1-7.5	8-12.5	13-21	22-30	31-50	51-60	61-80	81-130
Full U.S. GALLONS	22	33	40	46	71	94	128	147
Capacity LITERS	83	125	151	174	269	356	485	556
Weight LBS	130	160	180	195	325	465	560	650
Weight KGS	59	73	82	89	148	211	254	295
DIMENSIONS								
(A) Tank Diameter IN	18	18	18	18	24	24	28	30
MM	457	457	457	457	610	610	711	762
(B) Tank Height IN	20	30	36	42	36	48	48	48
MM	508	762	914	1067	914	1219	1219	1219
(C) Overall Height IN	41	51	57	63	59	71	71	73
Floor-Top Of Tank MM	1041	1295	1448	1600	1499	1803	1803	1854
CONNECTIONS								
(D) Vent/Return IN	1.25	1.25	1.25	1.25	2	2	2	2
MM	32	32	32	32	51	51	51	51
(E) Drain IN	.50	.50	.50	.50	1	1	1	1
MM	13	13	13	13	25	25	25	25
(F) Pump Outlet IN	1	1	1	1	1	1	1	1
MM	25	25	25	25	25	25	25	25
(G) Cold Water Inlet IN	.50	.50	.50	.50	.75	.75	.75	.75
MM	13	13	13	13	19	19	19	19
†(H) Overflow Opening IN	1	1	1	1	1	1	1	1
MM	25	25	25	25	25	25	25	25
(I) Pump HP								
1 Ph. Motor	.50	.50	.75	1.50	NA	NA	NA	NA
3 Ph. Motor	.50	.50	.75	1.50	3	3	5	5
(J) Pump Motor: RPM								
3450	3450	3450	3450	3450	3450	3450	3450	1725

†Overflow Opening must be piped to drain.

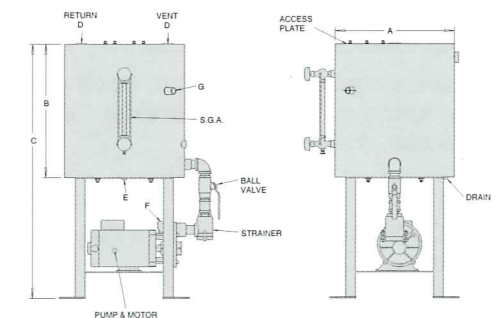

Optional preheat kits available. Preheat kits consist of sparge tube, ball valve, pressure reducing valve, solenoid valves, aquastat, well, thermometer, strainer, steam gauge assembly. Pressure reducing valve not required for low pressure units. On self-actuated preheat kits, the solenoid, aquastat and well are replaced by self-actuated valve. Not available for low pressure.

HT/VT 50-200 require two (2) sparge injector tubes.

Blow-Down Separators

Constructed with the finest quality materials, all compact Fulton Blow-Down Separators meet or exceed ASME Code and include special features to insure safe boiler blow-down. Fulton Blow-Down Separators also operate with minimum maintenance.

- Baffle plate absorbs steam flash and pressure.
- Steam is expelled safely through vent.
- Water and sludge pass through drain to sewer.
- 3" x 4" handhole for cleaning and inspection.
- Fully welded to ASME Pressure Vessel Code.
- Fast, easy hook-up to boiler.

Fulton's full line of heat transfer products includes:

- Fuel-fired vertical tubeless steam and hot water boilers.
- New VMP 2000 vertical flue pipe design boilers.
- Electric steam and hot water boilers.
- Pulse combustion steam and hot water boilers.
- Fuel-fired and electric thermal fluid heaters.

Larger blow-down separators are available. Consult factory.

Optional cooling kits available. Cooling kits consist of solenoid and ball valve, strainer, thermometer, aquastat, and well.

See Fulton VMP Brochure for the 40, 50, 60, 80, 100, 130 and 150 HP Pipe Design & Vertical Boilers.

Specifications/Dimensions/Connections

Model F	10	20	30	50	75	100	150	200
For Boiler Size HP	1-10	11-20	21-30	31-50	51-75	76-100	101-150	151-200
Max. Boiler Pressure	150	150	150	150	150	150	150	150
Capacity U.S. Gallons	7.9	17.4	22	35.6	40.8	58.75	70.5	157
	LITERS	30	66	83	135	154	222	594
Weight LBS	110	190	200	255	295	415	450	585
	KILOS	50	86	91	116	134	204	260
DIMENSIONS								
(A) Height IN	32	34	34	40	44	44	50	63
	MM	813	864	864	1016	1118	1270	1600
(B) Diameter IN	10.75	16	18	20	20	24	24	32
	MM	254	406	457	508	508	610	813
(C) Tank Height IN	20	20	20	26	30	30	36	48
	MM	508	508	508	660	762	914	1219
(D) Vent IN	3	3	3	3	4	4	4	5
	MM	76	76	76	76	102	102	127
(E) Drain IN	1.5	1.5	1.5	1.5	1.5	1.5	1.5	2
	MM	38	38	38	38	38	38	51
(F) Water Supply IN	.75	1	1	1	1	1	1	1
	MM	19	25	25	25	25	25	25
(G) Outlet IN	3	3	3	3	3	3	3	3
	MM	76	76	76	76	76	76	76
(H) Inlet IN	1	1.25	1.25	1.50	2	2	2	2
	MM	25	32	32	38	51	51	51
(I) Thermometer IN	.50	.50	.50	.50	.50	.50	.50	.50
	MM	13	13	13	13	13	13	13
(J) Handhole IN	3x4	3x4	3x4	3x4	3x4	3x4	3x4	3x4
	MM	76x102	76x102	76x102	76x102	76x102	76x102	76x102
(K) Inlet Height IN	16	18	18	18	18	18	18	26
	MM	406	457	457	457	457	457	660

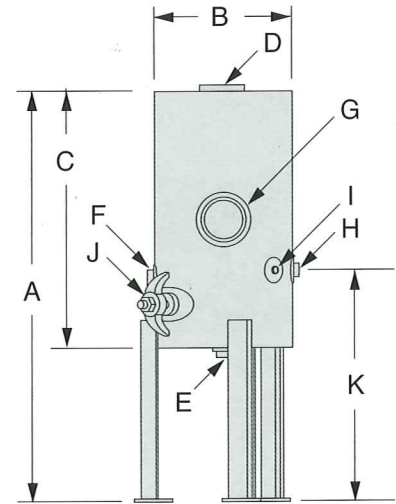

Fulton Boiler Works, Inc.

3981 Port Street, Box 257
Pulaski, NY 13142

Phone: 315-298-5121

Fax: 315-298-6354

www.fulton.com

A global manufacturer of steam, hot water and thermal fluid heat transfer systems.

Fulton Boiler Works, Inc.
Pulaski, New York

Fulton Heating Solutions, Inc.
Pulaski, New York

Fulton Thermal Corporation
Pulaski, New York

Fulton Boiler Works Great Britain, Ltd.
Bristol, England

Fulton Boiler Works Canada, Inc.
Aurora, Ontario

Fulton China, LLC.
Hangzhou and Ningbo, China



FBA12 BRO
R081205
Printed in USA