

**On-Premises
Softmount Washer-Extractors**



UniMac®

18 lb (8 kg) Washer-Extractor
25 lb (11 kg) Washer-Extractor
35 lb (16 kg) Washer-Extractor
55 lb (25 kg) Washer-Extractor
75 lb (34 kg) Washer-Extractor
100 lb (45 kg) Washer-Extractor
135 lb (61 kg) Washer-Extractor
165 lb (75 kg) Washer-Extractor



Expert Solutions from the Laundry Experts



Take a moment and step into the world of high tech product engineering, where UniMac washer-extractors are designed with innovative features that command top performance and durable steel construction that will stand the test of time. At UniMac, washer-extractors are considered more than just laundry equipment. They are key players in the success of commercial laundry facilities and, as such, must continuously achieve high levels of efficiency, quality and durability. UniMac always has maintained a standard of excellence in washer-extractor manufacturing that is recognized around the world. With over 50 years of engineering expertise, you can be assured that you are getting the best washer-extractors on the market that will meet your needs now, and in the future.

Tuned Suspension

Heavy-duty coil springs and strategically placed shock absorbers result in a tuned suspension system that absorbs out-of-balance load vibrations. The tuned suspension on

UniMac softmount models does not require special foundations. Strategically placed center of gravity and mass weight placement aid in controlling movement and results in a reduction of force transferred to the floor.

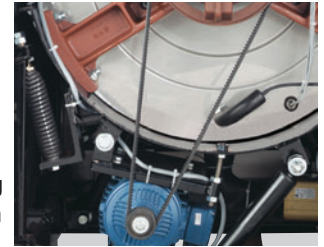

UX55 model shown.

High Tech Intelligent Drive System

The state-of-the-art *Intelligent Drive* provides flexibility and contributes to lower operating costs. The *Intelligent Drive* senses the speed (RPM) of the washer, allowing extreme accuracy even when the washer is reaching and maintaining high extraction speeds. The *Intelligent Drive* easily accommodates separate extraction speeds for blends, blankets and spreads, or heavy cotton towels. It's like having a custom designed machine for each linen type. A unique design allows the machine to be installed with single-phase electricity. The *Intelligent Drive* converts this to three-phase power for more efficient motor operation.



Shown with Programming Tool.

High-Speed Extract

The higher the G-Force during extraction, the lower the water retention of the fabrics being processed. 400+ G-Force* will reduce the gas or electricity used during the drying process by as much as 40% over 85 G-Force extract washers. This results in reduced drying and finishing time, reduced linting and extended linen life. High-speed extraction also can eliminate preconditioning of items to be ironed, saving energy while increasing production.

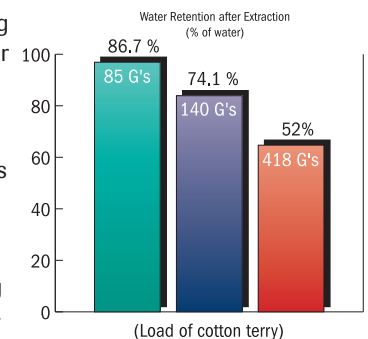

*UX55 model

Advanced Computer Control

UniMac's versatile computer control provides all the features you need to make your on-premises laundry operation efficient with the linen care performance you demand.



Operation Flexibility

The extremely flexible and easy-to-use control offers 39 pre-programmed settings with a maximum of 99 total programs. A variety of specialized needs can be met with the advanced computer control.

Programming options include:

- Overnight soak to assist with stain removal
- Precise temperature-controlled fills
- Thermal cool-down for complete control of water temperature

ProgressDisplay™

The easy-to-read digital text messaging, ProgressDisplay™, provides you with immediate feedback on every step in the washing process.



This feature is great for:

- Improving scheduling in your laundry operation
- Informing multiple operators of workflow
- Training new employees

Laundry Room Management

The cycle counter function assists management in monitoring proper cycle use and efficient use of time by laundry operators. The total hours run function allows management to properly schedule routine maintenance.

- Number of cycles
- Number of hours the machine has been operated

Value For Your Money

- Water reuse capable
- Three water inlets standard (18-75 lb models)
- Four water inlets standard (100-165 lb models)

Compact Design

Our unique compact design uses 34% less floor space than some competitors' models, giving our customers more room to manage their laundry.

18-55 lb models fit through a standard 36" door.

UniMac washers require 34% less space than the leading competitor

- UniMac Equipment
- Competitor Equipment

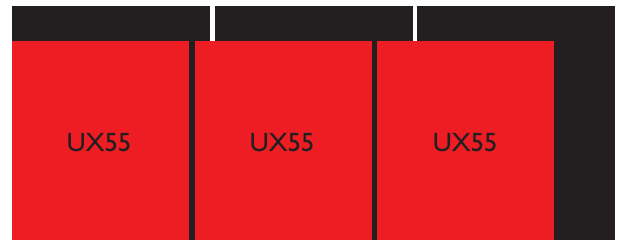

Multi-Faceted Supply Dispenser

The state-of-the-art liquid supply system for laundry chemicals offers convenience and dependability. It's factory installed for easy connection to the central liquid supply system providing six supply signals. For powder supplies, smaller models have three flush-down compartments mounted on the top of the washer. Larger models use removable cups. Laundry chemicals are mixed safely with water prior to coming in contact with fabrics.



Heavy-Duty Bearings and Seals

UniMac washer-extractors use heavy-duty precision bearings that are permanently lubricated for trouble-free operation. The double lip seals isolate the bearings from water and chemicals. Larger models use an automated lubrication system for ease of maintenance.

Five-Year Limited Parts Warranty

A five-year limited warranty is issued on the frame, basket, shaft, bearings and seals if failure or breakage should occur during normal operation due to defects in material or workmanship that would prohibit its further use. A three-year limited warranty also is issued to the original purchaser on all other parts.



Specifications

	UX18	UX25	UX35	UX55	UX75	UX100	UX135	UX165
Capacity - lb (kg)	18 (8.2)	25 (11.3)	35 (15.9)	55 (24.9)	75 (34.0)	100 (45.4)	135 (61.2)	165 (74.8)
Width - in (mm)	26" (660)	26" (660)	30 11/16" (780)	35 7/16" (900)	41 3/4" (1060)	47 1/4" (1200)	47 1/4" (1200)	51 1/4" (1300)
Depth - in (mm)	31 5/16" (796)	35 1/4" (896)	39 1/4" (998)	39 3/4" (1010)	45 1/8" (1147)	52 9/16" (1335)	59 1/16" (1500)	63 3/4" (1620)
Height - in (mm)	39 3/16" (995)	39 3/16" (995)	46 1/4" (1175)	59 1/16" (1500)	60" (1530)	75 9/16" (1920)	75 9/16" (1920)	82 11/16" (2100)
Cylinder Diameter - in (mm)	20 7/8" (530)	20 7/8" (530)	25 9/16" (650)	29 1/2" (750)	33 7/16" (850)	38 9/16" (980)	38 9/16" (980)	43 1/8" (1095)
Cylinder Depth - in (mm)	13" (330)	17 5/16" (440)	19 3/4" (500)	20 7/8" (530)	21 1/8" (537)	23 1/2 (597)	30 1/2" (775)	30 1/2" (775)
Cylinder Volume - cu.ft. (liters)	2.68 (76)	3.35 (95)	5.83 (165)	8.26 (234)	10.74 (304)	16.07 (455)	20.13 (570)	25.78 (730)
Door Opening Size - in (mm)	11 13/16" (300)	11 13/16" (300)	11 13/16" (300)	15 3/4" (400)	15 3/4" (400)	19 11/16" (500)	19 11/16" (500)	24 1/2" (622)
Door Bottom to Floor - in (mm)	11" (279)	11" (279)	15 5/8" (395)	22" (559)	22" (559)	25 1/2" (648)	25 1/2" (648)	28" (711)
Wash Speed - RPM	10-50	10-50	10-50	10-50	10-50	10-50	10-50	10-50
Distribution Speed - RPM	85	85	85	85	85	85	85	85
Extract Speed - RPM	500-1000	500-1000	250-1000	250-1000	250-1000	500-800	500-800	500-750
Extract G-Force	296	296	380	419	475	350	350	350
Water Inlet Conn. - in (mm)	3 x 3/4" (19)	3 x 3/4" (19)	3 x 3/4" (19)	3 x 3/4" (19)	3 x 3/4" (19)	4 x 3/4" (19)	4 x 3/4" (19)	3 x 1" (5.24) 1 x 3/4" (19)
Steam Inlet Conn. - in (mm)	3/8" (10)	3/8" (10)	3/8" (10)	3/8" (10)	3/8" (10)	3/8" (10)	3/8" (10)	3/4" (19)
Drain Conn. Size - in (mm)	2" (50)	2" (50)	2" (50)	3" (75)	3" (75)	3" (75)	3" (75)	2 x 4" (101)
Motor Size - HP (kW)	1 (.75)	1 (.75)	2 (1.5)	4 (3)	5 (4)	7 (5.5)	10 (7.5)	15 (11.5)
Voltage/Hz/Phase Circuit Breaker-FLA	X	200-240/50-60 1/3 • 15	200-240/50-60 1/3 • 15	200-240/50-60 1/3 • 15	200-240/50-60 1/3 • 15	N/A	N/A	N/A
	Q	N/A	N/A	N/A	N/A	200-240/50-60/3 • 20	200-240/50-60/3 • 25	200-240/50-60/3 • 30
	P	380-415/50-60/3 • 15	380-415/50-60/3 • 10	380-415/50-60/3 • 15	380-415/50-60/3 • 20	380-415/50-60/3 • 15	380-415/50-60/3 • 20	380-415/50-60/3 • 25
	N	440-480/50-60/3 • 15	440-480/50-60/3 • 10	440-480/50-60/3 • 15	440-480/50-60/3 • 20	440-480/50-60/3 • 15	440-480/50-60/3 • 20	440-480/50-60/3 • 25
Shipping Dimensions - in (mm)	H	46 1/16" (1170)	46 1/16" (1170)	59 1/16" (1500)	66 15/16" (1700)	68 1/2" (1740)	75 9/16" (1920)	75 9/16" (1920)
	W	28 3/4" (730)	28 3/4" (730)	33 7/16" (850)	38 3/16" (970)	44 1/8" (1120)	47 1/4" (1200)	47 1/4" (1200)
	D	33 1/16" (840)	33 1/16" (840)	37 3/8" (950)	43 5/16" (1100)	49 5/8" (1260)	52 9/16" (1335)	59 1/16" (1500)
Net Weight - lb (kg)	481 (218)	525 (238)	800 (363)	1177 (534)	1612 (731)	3351 (1520)	3627 (1645)	4630 (2100)
Shipping Weight - lb (kg)	514 (233)	564 (256)	844 (383)	1287 (584)	1722 (781)	3741 (1697)	4017 (1822)	5181 (2350)
Agency Approvals**	CE, ETLus, ETLc	CE, ETLus, ETLc	CE, ETLus, ETLc	CE, ETLus, ETLc	CE, ETLus, ETLc	CE, ETLus, ETLc	CE, ETLus, ETLc	CE, ETLus, ETLc

* Special order may require longer time, check with factory.

** Agency approvals may vary depending on configuration. Consult factory for details.

*** Operates on single or 3 phase system as single phase.

For the most accurate information, the installation guide should be used for all design and construction purposes. Due to continuous product improvements, design and specifications subject to change without notice. Features and certifications may vary by model. The quality management system of Alliance Laundry Systems' Ripon facility has been registered to ISO 9001:2000.

©Copyright 2008 Alliance Laundry Systems LLC

Printed in the U.S.A.



Components:

1. Top Supply Compartment (18 - 75 lb)
2. Controls
3. Cold Water Inlet
4. Hot Water Inlet
5. Cold Water Inlet
6. Vacuum Breaker
7. Electrical Connection
8. Drain Outlet (Dual Standard on 165 lb)
9. Front Supply Compartment (100 - 165 lb)
10. Supply Inlet
11. Water Inlet for Supply Box (100 - 165 lb)

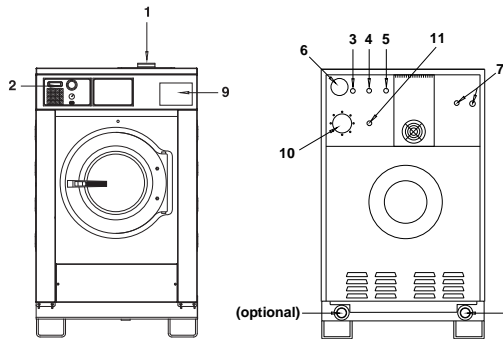

www.uniwash.com

Alliance Laundry Systems
Shepard Street, Ripon, WI 54971 Telephone: 1-800-587-5458

